



GAB. PRES. (O)93 / 4822 **ARCHIVO**

ANT.: S/Nº

MAT.: *Solicita opinión sobre propuesta*

Santiago,

15 SET. 1993

DE : SR. MARCELO TRIVELLI OYARZUN
Asesor de S. E. el Presidente de la República

A : SR. JUAN ESCUDERO ORTUZAR
*Secretario Ejecutivo de la Comisión Especial
de Descontaminación de la Región Metropolitana*

Remito adjunto al presente una proposición de "Sistema de Monitoreo del Medio Ambiente" para Santiago, emitida por Orlando Sáenz y Cía., sobre la cual le agradezco emitir su opinión.

Le saluda atentamente,



Marcelo Trivelli Oyarzún

Incl.: Lo indicado

Distribución:

- 1. Secretaría Ejecutiva de la Comisión Especial de Descontaminación de la Región Metropolitana*
- 2. Archivo Presidencial ✓*
- 3. Correlativo 048/93*

MTO/icm

MEMORANDUM PROPOSICIÓN DE SISTEMA DE MONITOREO DE LA POLUCIÓN PARA SANTIAGO.

El Sistema de Monitoreo de la Polución del aire para la ciudad de Santiago que se propone, se ha dividido en cuatro fases de implementación, según se explica en documento técnico, y cuyos costos aproximados son los siguientes:

Etapa	Descripción	Costo CIF UK	Costo Local	Costo Total
1	Reemplazo de los instrumentos de las estaciones de monitoreo existente en la actualidad (medidores de CO, SO ₂ , NO, NO _x hidrocarburos y ozono).	US\$900.000	US\$350.000	US\$1.250.000
2	Suministro e instalación de diez estaciones meteorológicas ubicadas estratégicamente en la ciudad. (Velocidad y dirección del viento, temperatura e incidencia solar, lluvia, presión atmosférica y humedad relativa.).	US\$200.000	US\$350.000	US\$ 550.000
3	Suministro e instalación de cinco estaciones de monitoreo de partículas en suspensión y ozono.	US\$500.000	US\$300.000	US\$ 800.000
4	Suministro e instalación de 25 sensores de monitoreo ambiental, para NO ₂ , CO, SO ₂ e hidrocarburos generales. Utilizará red de comunicaciones proyecto SCAT de Control de Tráfico.	US\$650.000	US\$450.000	US\$1.100.000
	Subtotal			US\$3.700.000
	- Grant Gobierno Británico			US\$ 800.000
	Total Neto			US\$2.900.000
	IVA			US\$ 670.000
	TOTAL			US\$3.570.000

END

Monitoreo del Medio Ambiente

1. Introducción

Actualmente, Santiago posee cuatro estaciones fijas para el monitoreo de variables ambientales, meteorológicas y una estación móvil, utilizada para monitorear las áreas de potenciales problemas.

El equipamiento con que cuentan estas estaciones es bastante antiguo, lo que causa serios problemas para su mantención y un costo elevadísimo. Adicionalmente, la ubicación de las estaciones no permite medir muchas de las variables atmosféricas que se requieren.

2. Proposición de Sonda y Siemens Plessey

De acuerdo a las conversaciones sostenidas con los expertos chilenos en estas materias, se propone la modernización del sistema de monitoreo en la ciudad de Santiago. La implementación de este sistema se propone que sea realizada en tres etapas.

Las estaciones de monitoreo actuales, si bien fueron implementadas en 1987 y son manejadas por computadores razonablemente modernos, los instrumentos con que cuentan son mucho más antiguos, teniendo mucho de ellos más de 10 años.

Por ello, la primera etapa que se considera importante efectuar tan pronto sea posible, es reemplazar los instrumentos existentes, por instrumentos de última generación.

A continuación, es importante agregar diez estaciones meteorológicas, ubicadas en forma adecuada, que monitoreen lo siguiente:

- Velocidad del viento.
- Dirección del viento.
- Temperatura.
- Incidencia solar.
- Lluvia caída.
- Presión atmosférica.
- Humedad relativa.

Luego, y en forma simultánea se recomienda implementar estaciones de medición de ozono y de partículas de polvo; para ello, se utilizarán instrumentos de última generación (medidores de ozono fotomáticos y medidores de partículas continuas tipo PM10).

Por último, se propone implementar una red de aproximadamente 25 sensores de contaminación que utilicen celdas electroquímicas para medir NO₂, CO y SO₂ y botón catalítico para medir hidrocarburos generales.

Estos instrumentos son de tamaño pequeño y bajo consumo, por lo que se instalarán dentro de los controladores de semáforos de la ciudad.

La idea es aprovechar la red de comunicaciones que se instalará en el contexto del proyecto SCAT, (Sistema de Control de Tráfico Centralizado para la Ciudad de Santiago); de esta forma los datos medidos por el sistema de Monitoreo de Polución serán enviados por la red de transmisión de datos del sistema de control de tráfico, el que cubrirá 1080 intersecciones de la ciudad.

La información llegará al computador del sistema de Tráfico, desde donde será extraída y enviada a la red de monitoreo ambiental existente.

3. Financiamiento

En el contexto del mismo proyecto SCAT, es posible extender la donación del gobierno británico, que alcanza el 35% del valor CIF de los equipos utilizados por el sistema de monitoreo y servicios de origen británicos asociados.

2. TECHNICAL PROPOSAL

2.1 Introduction

This proposal has been produced for the Comision Especial De Descontaminacion Region Metropolitana, Santiago, Chile. It identifies the Environmental Monitoring Options appertaining to the Traffic Control Proposal for Santiago offered to Unidad Operativa DE Control DE Transito by SONDA/Siemens Plessey Controls Ltd (SPCL).

A meeting was held between SONDA, SPCL and Juan Escudero Ortúzar (Secretario Ejecutivo) in December 1992 to identify the current Environmental Monitoring conducted within Santiago and the future Monitoring needs of the Comision, and the relationships between traffic congestion and Environmental impact.

2.2 Background

Santiago experiences severe air pollution, the primary cause of this pollution comes from road traffic. The geographical siting of the city and the climatic inversion layer prevents the normal dispersion of pollutants.

Four Fixed and one Mobile Monitoring system operate in Santiago. The fixed stations are concentrated in the centre of the city, the mobile station is used to monitor potential problem areas. A further 2 mobile units are understood to be added.

Information gained from monitoring has identified Ozone and Particulates as the constituents of the pollution causing the main concerns. The monitoring has also assisted in enabling legislation to be introduced to restrict traffic entry into the city.

2.3 Future Objectives of the Comision

It is intended that further pollution monitoring is carried out and to identify particular problem areas of the city. To do this the comision has obtained two more further mobile units.

These units will be used to measure pollution levels in other areas of the city not connected to the network. This information could be used to determine the ideal sites for further fixed stations monitoring Ozone and Particulates. These stations would then be connected to the network.

The current stations also have the ability to measure Meteorological conditions, however this data is inaccurate due to the siting of the meterological equipment. It is the comisions intention to install further weather stations sited in positions where the measurements will be accurate. This data would be added to the network, this will enable the comision to determine pollution distribution and its behaviour relative to climatic conditions.

The current fixed stations contain old Monitoring Equipment which is almost obsolete. Although the Systems were integrated onto a network in 1987 some of the equipment is considerably older and now obsolete. This is causing problems with respect to maintenance and obtaining spares, the cost per annum for maintenance alone above is approx \$250K. The comision is faced with the decision on whether to replace the analysers or to continue to maintain them if possible.

Traffic pollution is the major cause of air pollution in Santiago. Installation of the proposed city wide traffic control system should have a significant effect on the reduction of pollution levels. Approximately xxx million litres of fuel per annum are burnt into the atmosphere in Gran Santiago by road vehicles.

"A major contribution (to the reduction of pollution) can be made by the UTC System by reducing the number of stops that are made at traffic signals and therefore the amount of time that vehicles spend decelerating, idling, and accelerating". The reductions of the main pollutant are estimated as CO 30% and No 23%.

However the ability to alter traffic control and further reduce emissions is attractive to the comision but not an objective currently being considered by them. This type of data and consequent control influence could be readily added to the traffic control system, low cost sensors measuring pollution levels could be installed at certain junctions. This data would then be transmitted through the Traffic Control System network back to the Main Computer. The data could then be available for extraction or used in conjunction with the traffic control to implement traffic restrictions etc.

2.4 Possible Options Related to the Traffic Control System for Santiago

Siemens Plessey Controls in conjunction with SONDA have tendered for the Traffic Control System for Santiago. The United Kingdom content of this tender will be eligible for an overseas development aid grant and financing through the Midland Bank. Included within that tender were environmental options which have not been defined.

This proposal identifies these options in detail. To take advantage of the UK financing any options for the Environmental Monitoring must be ordered through SONDA and SPCL.

This proposal identifies two possibilities for the Comision De Descontaminacion. Firstly to provide instrumentation which will allow for replacement of existing obsolete analysers, the provision of weather stations, and a further number of Ozone and Particulate monitoring stations. Secondly to provide a fully integrated Environmental and Traffic Control System with a number of monitoring points around the city. Data from this network could then be available to supplement the existing Pollution Monitoring Network in the city and also to provide a measure of control in implementing changes to the traffic control and further reduce these emissions.

Option 1 Instrumentation for Existing Pollution Monitoring Network

- a) Replacement of Analysers on the existing network.

It is understood that the existing 5 stations are equipped with the following analysers:

<u>Qty</u>	<u>Variable(s) Measured</u>	<u>Manufacturer/Model</u>
4	CO	Beckman, 866
1	CO	Horiba APMA 300E
4	SO2	Beckman, 953
1	SO2	Horiba, APSA 300E
4	NO/NOX	Beckman, 952A
1	NO/NOX	Horiba, APNA 300E
4	Hydrocarbons	Beckman, 400
1	Hydrocarbons	Horiba, APHA 300E
1	Ozone	Beckman, 950A
4	Ozone	Horiba, APOA 300E

The Beckman company in the USA no longer exists and consequently spares support is virtually impossible. The analysers purchased from Horiba, although still supported, are not the latest generation, and longer term support is questionable.

The stations are equipped with data loggers provided by SONDA in 1987 and Software at the Master station is still suitable for current needs. However the age of the analysers will mean that imminent replacement is necessary for reliable and meaningful data retrieval.

These instruments could be replaced by the latest generation of Ambient Air Analysers. Siemens could provide Lear Siegler (Monitor Labs) 9800 series analysers. Manufactured in the United Kingdom.

Full details of these analysers are enclosed in Appendix 1. These analysers would interface with the existing data loggers and would be compatible with the Software at the Master Station. Some minor modification to the calibration routine may be necessary.

These instruments are fully supported in Chile by local agents, and a full set of spares and consumables would be provided within the proposal.

Installation of the analysers would utilise existing enclosures and instrument racks and could be performed with the minimum interference to the operation of the existing network.

SONDA would be responsible for the installation/commission and any minor modifications necessary to the data loggers/and calibration routine. As they provided the integration of the original systems they are already familiar with this type of work.

Full documentation to support the system would also be provided.

b) Supply of Meteorological Stations

As the comision already intends to add 10 meteorological stations to the network these can be provided by Siemens Plessey Controls. The stations would be installed at locations as directed by the Comision. The stations would monitor the following:

- Wind Speed
- Wind Direction
- Temperature and Solar Incidence
- Rainfall
- Atmospheric Pressure
- Relative Humidity

A data logger and Communications MODEM would also be provided and the sensors would be mounted on a rigid frame.

A full specification of the meteorological station is enclosed in Appendix 2.

c) Supply of Ozone and Particulate Monitoring Stations

This would be a complete monitoring station dedicated to the measurement of Ozone and Dust Particulates.

Ozone would be measured using the latest generation Ozone Photometer. The analyser has been designed to meet USEPA requirements for an Ozone primary/transfer standard as required for the calibration of Ozone Analysers.

The particulate monitor would perform continuous PM10 monitoring to US EPA standards, using a filter Based Mass Measurement technique.

The analysers would be mounted in an Equipment rack within a robust weatherproof and secure steel cabinet. Calibration facilities, a Data logger and communications modem would be included.

SONDA would be responsible for the installation/commissioning and integration of these systems onto the exciting environmental monitoring network and any changes necessary to the software.

A full specification for these stations is enclosed in Appendix 3.

2.5 Option 2 Integrated Traffic and Environmental Monitoring System

The situation in Santiago is such that the city already has a dedicated Air Pollution Monitoring Network which the Comision intends to expand, however installation of the traffic control system could allow the commission to install additional pollution monitoring sensors and supplement the information already being gathered.

The ability to monitor the air pollution at a relatively large number of points with all of the information collected and displayed at one control station is usually very expensive. Existing techniques utilise ambient air analysers housed in cabins connected to the master station utilising either telephone or radio links. This requires a significant investment into analysers and communications systems and the ongoing cost of the data network.

However other techniques are available to those cities who have installed or who are about to install a traffic control system. The installation of a traffic control system involves a large number of data entry points ie traffic lights and sensors, and a distributed communications network feeding this information back to a central control station every second. Connection of pollution monitoring devices to this network can be achieved relatively easily. This data will then be available at the central control station to provide a complete CITY wide pollution and Traffic Control System. Pollution data and Traffic data would be available at the same point.

The pollution sensor will consist of small low power unit utilising electrochemical cells to measure NO₂, CO and SO₂ and a catalytic bead for General Hydrocarbons. The output from the sensor unit would be provided in a digital format to interface directly into the traffic network as shown in figure 1.

The data would be extracted from the traffic control system and passed to the current environmental monitoring network.

To supplement the estimating network a further 25 traffic pollution sensors could be installed adjacent to traffic lights around the city. The sensors would be mounted within the traffic controller and data sent directly over the traffic control network.

This would allow the authority to make changes to the traffic control to influence a reduction in associated pollution.

A full specification for these sensors is included in Appendix 4 along with comparisons on operational life and comparisons in accuracy against traditional ambient air analysers.

SCAT O System with Integrated Pollution Monitoring

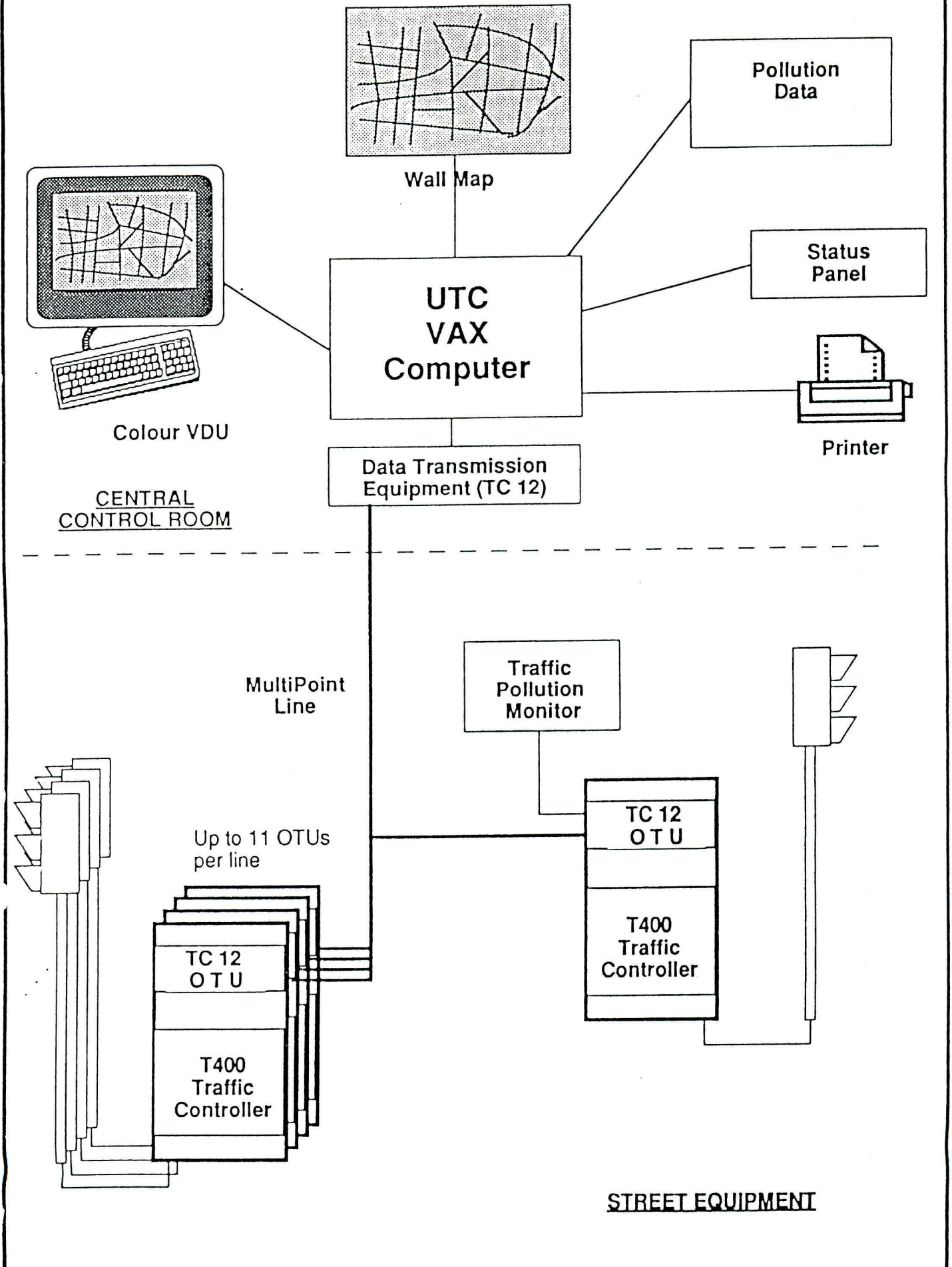



Orlando Sáenz Rojas - Presidente Ejecutivo
(izquierda) y
Francisco Sáenz Rica - Gerente General
(derecha).

Orlando Sáenz Rojas - Chairman
(left) and
Francisco Sáenz Rica - Managing Director
(right).

■ *EL NACIMIENTO DE LAS OFICINAS DE NEGOCIOS.*

A raíz de la complejidad y competitividad de los diferentes mercados, nacen las llamadas "Oficinas de Negocios", donde un conjunto interdisciplinario de profesionales presta una asesoría integral y eficiente a aquellas personas u empresas interesadas en realizar un negocio exitoso.

Cada integrante de este grupo, además de reunir una alta capacidad profesional y amplia experiencia, debe poseer grandes condiciones de gestión en los más diversos sectores (público, financiero y privado). La fórmula para formar una buena oficina de negocios se sustenta en la combinación de ambos requisitos; vale decir, la conjunción de una amplia capacidad profesional y actividad pública y privada de cada uno de sus miembros en el medio.

Algunas de las tareas fundamentales que caracterizan a este rubro, son la captación de recursos para una buena iniciativa, la obtención y negociación de créditos operacionales o de inversión y la adecuación de pasivos a la capacidad de generar excedentes.

■ *ORLANDO SAENZ & CIA - PROFESIONALES ASOCIADOS: La trayectoria de una Gran Oficina de Negocios.*

La acumulación de recursos de capacidad profesional, experiencia y relaciones tanto nacionales como internacionales, durante más de 20 años, hacen de esta organización la mejor oficina de negocios y de asesoría financiera existente en el país. Entorno a la dilatada experiencia de su Presidente y Socio Principal, el ingeniero y economista Sr. Orlando Sáenz R. (ex-Presidente de la Sociedad de Fomento Fabril, la Asociación de Empresarios Metalúrgicos y de la Asociación de Industriales Latinoamericanos, ex-Asesor Económico del Ministerio de Relaciones Exteriores, Asesor del Desarrollo Industrial de O.N.U.D.I., ex-Representante de Chile ante el F.M.I. y ante la Asamblea General de la O.N.U. presidente y director de bancos, financieras y empresas comerciales, industriales y de todo tipo en Chile y diversos otros países), se han reunido distinguidos profesionales de todas las disciplinas

■ *THE RISE OF BUSINESS OFFICES.*

The complexity and competitiveness of today's different markets has led to what is known as "Business Offices", an interdisciplinary body of professionals who provide overall advice to persons and companies interested in successful business operations.

Each member of such a group must necessarily have unmistakable skills and experience, being permanently accepted as an undisputed, reliable authority by the public, private, and financial sectors. For the key to successful business office is twofold: it is a combination of high professional ability and the public and private influence gained by each individual in the staff.

Part of the work in this field aims at collecting and analyzing resources to be assigned and properly used for credit and investment purposes along with surpluses thus generated, relying on consistently realistic and accurate liability handling.

■ *ORLANDO SAENZ & CIA - PROFESIONALES ASOCIADOS: The history of a Great Business Office.*

Its professional qualifications, insight, national and international experience and contacts for over 20 years are an indication that this is the best business office for financial advice in this country. The judgment and wisdom of its Chairman and Senior Partner - the well known engineer and economist Mr. Orlando Sáenz R., a former President of Sociedad de Fomento Fabril, Asociación de Empresarios Metalúrgicos, and Asociación de Industriales Latinoamericanos; also a former Economic Adviser to the Ministry of Foreign Affairs, Adviser to U.N.O.I.D., Chile's representative at the I.M.F. and U.N.O., director of banks, financial agencies, business and industrial companies of sorts in Chile and abroad - has made possible the selection of outstanding professionals and is full guaranty of excellent advice to help investors in every respect.

requeridas para asegurarles a los clientes, la excelencia de un servicio de asesoría que respalde cabalmente sus inversiones.

Durante esta larga trayectoria profesional, "Orlando Sáenz & Cia." se ha encargado con pleno éxito, desde idear y planificar el mayor Shopping Center existente en Chile (Parque Arauco) hasta organizar y asesorar a la primera sociedad mixta Chileno-Soviética que tiene nuestro país (Sovchile S.A.).

Entre esos extremos, ha tenido participación en la negociación de créditos nacionales e internacionales para empresas de los más variados tipos. Asimismo ha estructurado convenios de servicios de pasivos financieros para grandes empresas chilenas y ha traído inversiones extranjeras a Chile bajo las diversas formas previstas para ello. Además, ha funcionado como intermediaria en la reapertura de relaciones comerciales entre Chile y países de Europa Oriental. "Orlando Sáenz & Cia.", se ha hecho cargo de la compra y venta de empresas y activos por cuenta y en representación de inversionistas nacionales y extranjeros, obteniendo grandes contratos públicos en Chile para proveedores y contratistas de numerosos países. También ha ayudado eficazmente a varias empresas chilenas a exportar bienes y servicios, contribuyendo a su instalación en mercados tan importantes como E.E.U.U. y Europa Occidental o tan excitantes como Sudáfrica y la U.R.S.S.. Durante estos fructíferos años, ha creado corresponsalias de gran nivel de calidad en E.E.U.U. y diversos países de Europa Occidental, Sudáfrica y casi todas las naciones latinoamericanas, abriendo y extendiendo su vasta red hacia los más remotos mercados.

All along this time, "Orlando Sáenz & Cia." has successfully planned and accomplished the creation of highly ambitious enterprises: from the largest Shopping Center in Chile (Parque Arauco) to Sovchile S.A., the first Chilean-Soviet joint venture in our country organized and technically assisted by "Orlando Sáenz & Cia."

It has, in the meantime, taken part in national and international negotiations for credit on behalf of all sorts of companies, financial liability agreements for large Chilean corporations, and foreign investment in Chile. It has additionally mediated for the reopening of business relations between Chile and East European countries. "Orlando Saenz & Cia." has undertaken the sale and buyout of companies on behalf of national and foreign investors while at the same time making successful contracts in Chile for suppliers and contractors from a number of countries. It has assisted several Chilean companies exporting goods and services, finding a place for them in major U.S. and Western Europe markets or in such exciting places as South Africa or the U.S.S.R. During all these fruitful years, it has developed high-level contacts in the United States, Western Europe, South Africa and virtually all of the Latin American countries, thus opening and extending its action to far-away markets.

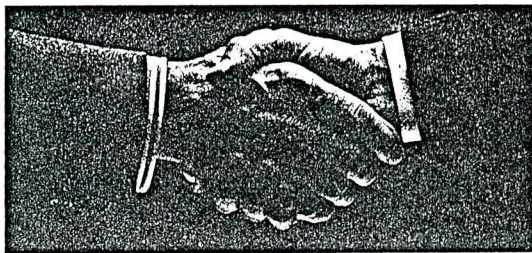

arkets has
y body of
interested

nistakable
d, reliable
he key to
ofessional
tual in the

resources
ses along
d accurate

S
Office.

ernational
is the best
d wisdom
economist
nto Fabril,
industriales
linistry of
the I.M.F.
industrial
election of
ce to help



"Orlando Saenz & Cia., Profesionales Asociados" is the business office with the highest prestige for efficiency in Chile. This is the only one of its kind in a position to give overall advice to national as well as foreign investors thanks to its vast knowledge, experience, and highly qualified professionals operating all over the world.

Orlando Saenz R. needs hardly be presented. His well known professional and political profile, as well as his advising staff, is self-evident guaranty for assistance to all clients requesting the services of this great company.

"Orlando Saenz & Cia., Profesionales Asociados" es la oficina de negocios de mayor prestigio y eficiencia en Chile. Se trata de la única empresa del rubro capaz de prestar una asesoría integral tanto a inversionistas nacionales como extranjeros, gracias a la experiencia y conocimiento demostrada por sus profesionales en diversos mercados del mundo.

La figura de Orlando Saenz R. prácticamente no requiere presentación. Su dilatada trayectoria empresarial y política unida al apoyo de un excelente staff asesor, el cual está conformado por figuras relevantes en las más diversas áreas, constituyen un verdadero aval para los clientes que han contratado sus negocios a esta gran compañía.