

REPUBLICA DE CHILE

PRESIDENCIA



JUAN G. ALQUINTA

P O BOX 393

S CLE ELUM, WA. 98943-0393

REPUBLICA DE CHILE
PRESIDENCIA
REGISTRO Y ARCHIVO

NR. 92 / 15678
A: 14 JUL 92

P.A.A.	<input type="checkbox"/>	R.C.A.	<input type="checkbox"/>	F.W.M.	<input type="checkbox"/>
C.B.E.	<input type="checkbox"/>	M.L.P.	<input type="checkbox"/>	P.V.S.	<input type="checkbox"/>
M.T.O.	<input type="checkbox"/>	EDEC	<input type="checkbox"/>	J.R.A.	<input type="checkbox"/>
M.Z.C.	<input type="checkbox"/>				

CLT

ARCHIVO

"ZACKLIFT END MOTOR INC.".-

WA. STATE. 6 DE JULIO - 1992

JUAN G. ALQUINTA

P.O. BOX 393.-

SOUTH CLE -ELUM,WA. 98943-0393.-

FAX 509-674-2136, U.S.A.-

"ZACKLIFT END MOTOR INC".-
TO: CHILE AND LATIN AMERI-
CA.SERVICIOS Y GARANTIA.

EXCMO. SR. PRESIDENTE DE CHILE.-
DON PATRICIO AYLWIN
PALACIO DE GOBIERNO, LA MONEDA.-
*SANTIAGO DE CHILE.-

REP: EN CHILE: DON RUBEN B.
RIQUELME LOBOS Y EDGAR B.
ALQUINTA AGUIRRE.-

CON TODO RESPETO Y ADMIRACION LO SALUDA UN CAMARADA Y COM-
PATRIOTA CHILENO, QUE HOY RADICA EN LOS ESTADOS UNIDOS
DE NORTEAMERICA Y QUE REPRESENTA A UNA DE LAS INDUSTRIAS
MAS IMPORTANTE LLAMADA ESTA :

"ZACKLIFT END MOTOR INC" . LE OFRECE
A CHILE POR SU INTERMEDIO LOS PRODUCTOS ZACKLIFT PARA
EL USO PUBLICO O COMO PARA EL ARMY EN CHILE.-
LA INDUSTRIA EXPORTA A ARABIA SAUDITA Y A EUROPA. YO TENGO
LA REPRESENTACION LEGAL PARA TODA LATINO AMERICA Y EN MI RECORD
DE 1988. LE ENVIE AL EX-PRESIDENTE DON AUGUSTO PINOCHET U. SIN
TENER RESPUESTA DE ESTA GRAN OFERTA DE "ZACKLIFT END MOTOR
INC ". OJALA CHILE TENGA PRESENTE QUE ES UN VEHICULO DE
SERVICIOS A LOS HABITANTES EN ACCIDENTE O EN PROBLEMAS EL VEHI-
CULO EN CARRETERAS DE ALTA PISTA O EN LA CIUDAD.-

*ZACKLIFT ES UNA GRUA HIDRAULICA Y ES MFG.
DE ACUERDO A LAS TECNICAS DE LA INGENIERIA MODERNA CON ALTA TECNOLOGIA.
***** SI SU EXCMO SR. PRESIDENTE DON PATRICIO AYL
WIN DESEA IMPORTAR PARA CHILE TENDRA LOS MEJORES PRECIOS INTER-
NACIONALES PUESTO POR LA INDUSTRIA , "ZACKLIFT END MOTOR INC".-

HE ENVIADO UNA REPRESENTACION LEGAL PARA OFRECER ESTE PRODUCTO EN CHILE
POR INTERMEDIO DE MI HIJO EDGAR ALQUINTA AGUIRRE, LE ENVIADO LOS PRECIOS Y
TAMBIEN VIDEOCASSETTE PARA QUE VEAN EN CHILE LA AVANZADA Y REVO
LUCIONARIA GRUA HIDRAULICA MAS USADA HOY LOS ESTADOS UNIDOS Y EUROPA.
LO SALUDA ATTE A UD.

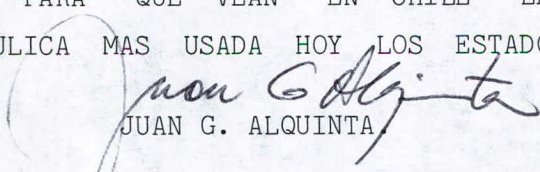
JUAN G. ALQUINTA

ARCH?

JGA.

fax ; 671-5909 EN SANTIAGO DE CHILE.-

92. DON RUBEN R. Y EDGAR ALQUINTA A SUS ORDENES EN CHILE.-



1509 B 74 4426

Manufactured by
EAST END MOTORS, INC.
1102 EAST FIRST STREET
CLE ELUM, WA 98922
USA

June 10, 1992

To Whom It May Concern:

Juan G. Alquinta and Edgar Boris Alquinta of Polo to Polo, Santiago De Chile are authorized representatives of Zacklift. Their authority covers all Latin America.

Please feel free to contact me directly for further information.

Sincerely,

Susan Newton
Susan Newton
Vice President, GM

Juan G Alquinta
The Polo to Polo INC

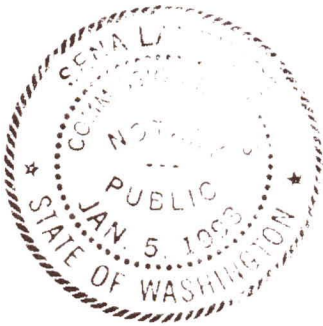

Subscribed and sworn to before me
this 11th day of
June, 1992
Susan Zackovich Newton
Notary Public in and for the State
of Washington,
Residing at South Cle Elum
My notary commission expires 1-5-93

SUSAN ZACKOVICH NEWTON
GENERAL MANAGER V.P.

WASHINGTON STATE 360.674.4426
TOLL FREE 1-800-257-0600
FAX 509-674-5267

A DIV. OF EAST END MOTORS, INC.
1102 EAST FIRST STREET
CLE ELUM, WA 98922



ZACKLIFT Z4500[®]

PATENT NO. 4,775,285

Made By The Retrofit Experts.

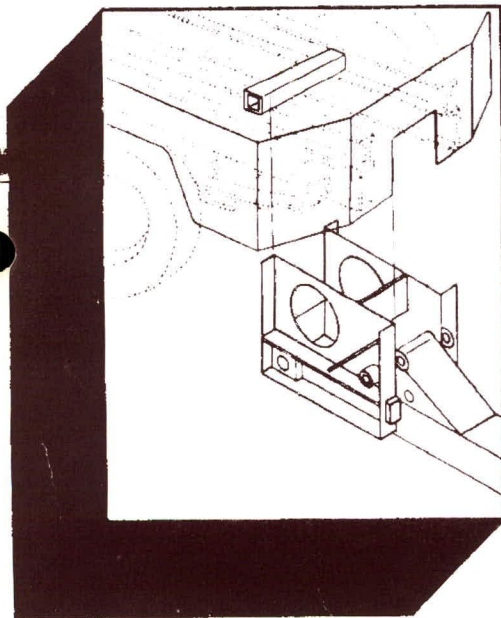
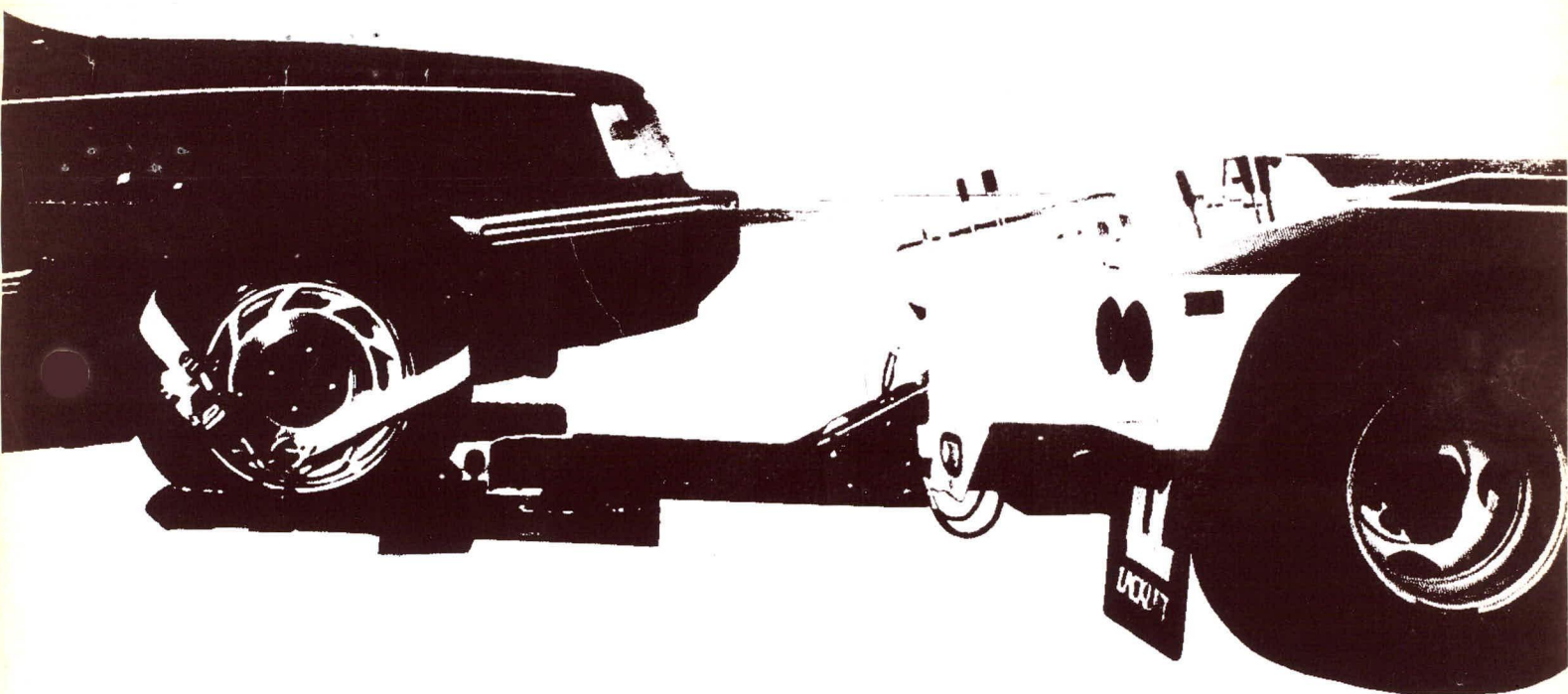

**NOW YOU DON'T HAVE TO
CHOOSE BETWEEN
EASY INSTALLATION,
STABILITY OR
PROTECTION FOR
YOUR BODY & STRENGTH**

**THE LEADER IN RETROFIT
TECHNOLOGY - GIVES YOU ALL THREE.**

4500 POUND LIFT RATING AND 12,000 POUND TOW RATING *
makes Zacklift the most powerful in its class. The Z4500 is backed by Zacklift's unmatched reputation for quality, strength and service.

Fully hydraulic and carefully engineered for easy installation with a minimum of requirements, the Z4500 converts any wrecker, mechanical or hydraulic, to a money making damage-free system.

*Tow rating with use of motorhome forks & brackets.

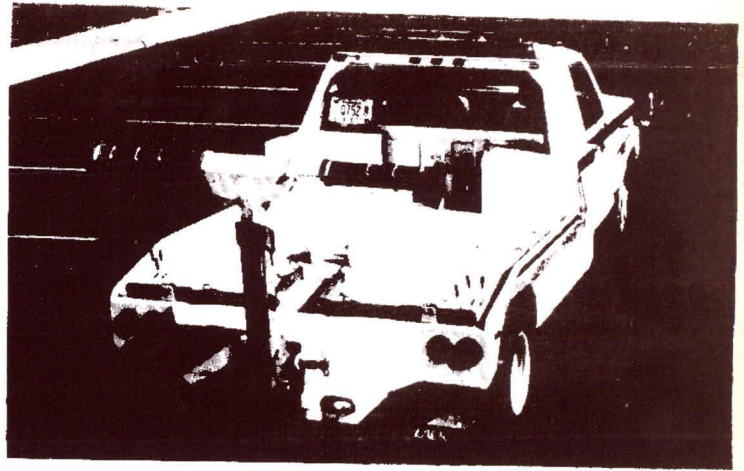
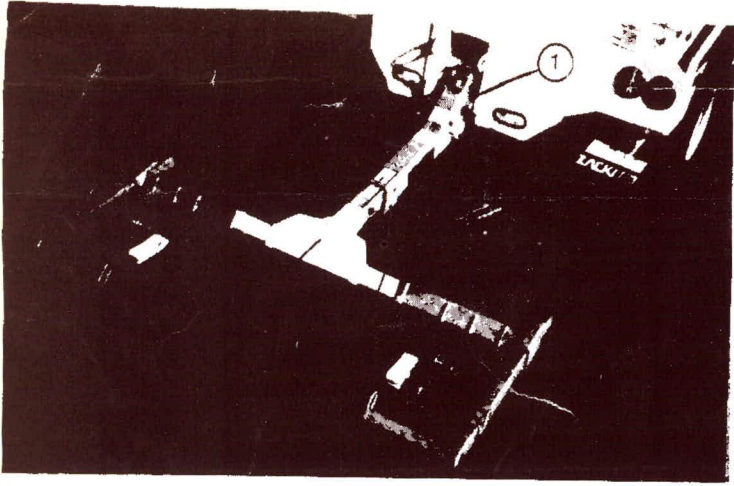

1. Zacklift is in a class by itself when it comes to its power down and up tilt cylinder and Dual Load Hold System. A built-in check valve, requiring no hoses or tubing, together with a mechanical locking system provide for the utmost towing safety. 2. The Zacklift Z4500 features the same rugged grid assembly as Zacklift's medium duty wheel and frame lifts. 3. Grid Sliders adjust to accommodate the narrowest compact to the widest van. 4. Zacklift's self-locking "L" Bars require no pins or rods, easily sliding into place with the grid at any angle. Variable "L" Bar settings allow for any tire width. 5. Timken Roller Bearings in the critical pivot hub provide years of trouble free towing. This unbeatable pivot action allows for hookup at even the tightest angles. 6. The removable grid cross bar option allows for easy sling use. 7. When not in use the Z4500 stores in a compact carrying position within 9 inches of the tailboard.

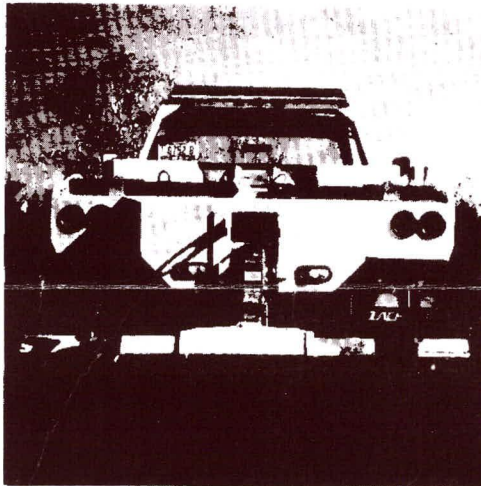
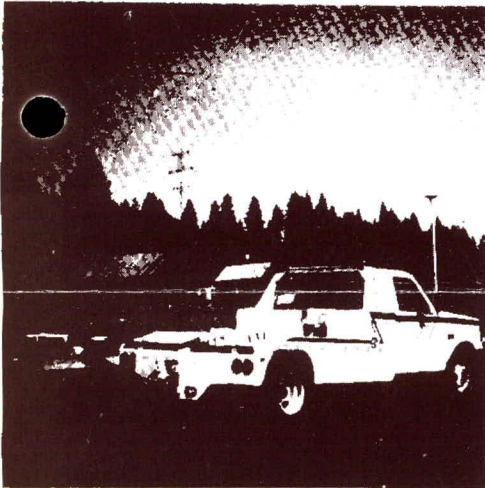

8. Now you can recover it all with Zacklift's 63 inch extension from tailboard to forks. 10° downward tilt and unlimited up tilt is no problem for the Z4500's efficient lift and tilt combination. 9. Motorhome Forks and Brackets are an option which puts you a step ahead of the competition by adding the capability to lift by the frame or axle. 10. Even motorhomes are within your reach with the powerful lift of the Z4500.

FINANCING AVAILABLE



1102 E. 1ST ST.
CLE ELUM, WA U.S.A. 98922
800-257-0600 IN WA (509) 674-4426

BULK RATE
U.S. Postage
PAID
Cle Elum, WA
PERMIT NO. 16

ZACKLIFT.

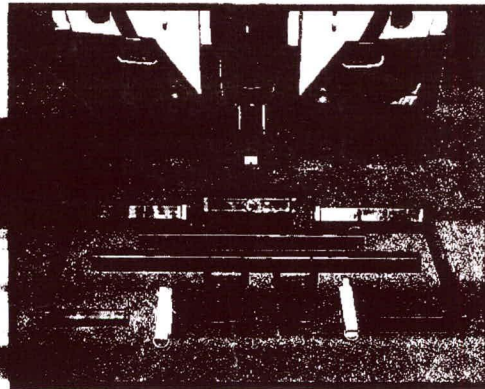
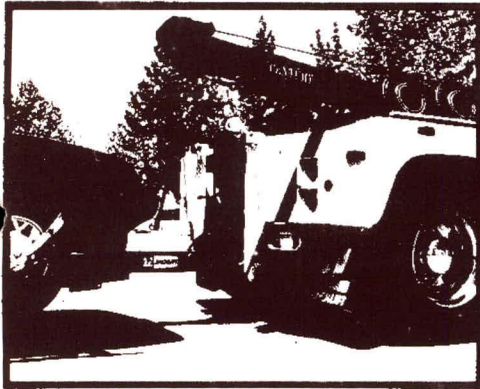

standard equipment...

Standard equipment includes everything necessary for wheel lifting: The Industry's best self-locking "L" bars allow for wheel lifting at any angle. This practical assembly adjusts to accommodate the narrowest compact to the widest van. Versatile motorhome frame forks and brackets adjust to any width and two height settings and can be positioned to receive on either side of the cross bar. Two cross bars measuring 43 and 60 inches are included. Tow bar use is easy with the removable grid cross bar which conveniently allows tow bar or sling to flop over the Zacklift when in the storage position.

two medium duty frame lift units to choose from...

	Z6500	Z7000
Retracted lift rating	6,500 lbs.	10,000 lbs.
Extended lift rating	5,000 lbs.	7,000 lbs.
Tow Rating	40,000 lbs.	40,000 lbs.
Weight of Unit	800 lbs.	900 lbs.
A — Reach	64 in.	74 in.
B — Reach with 10 in. Bus Extensions	74 in.	84 in.
C — Reach from axle to Bus Extensions (varies)	107 in.	117 in.
D — Distance from tallboard when stored	8 in.	8 in.
E — Upward tilt, maximum lifting height	15°	15°
F — Tilt below ground	10° 10 in.	10° 10 in.
G — Downstroke on lift cylinder	13 in.	13 in.

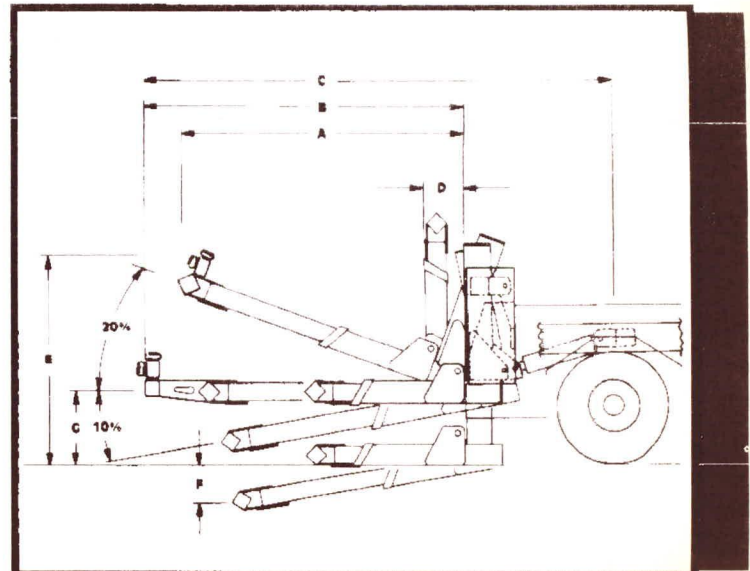

Zacklift does one thing and they do it well. No one else in the towing industry has more experience in add on underlifts than the people at **Zacklift**.

Zacklift's medium duty wheel/frame lifts feature **Zacklift's** patented lift and tilt combination. Three separately functioning cylinders provide the unique ability to position the extension arm flat on the ground and add the 25° tilt motion with 10° below ground tilt and 15° above ground tilt. A necessary combination for scooping under low air folles in one operation. A direct up lift without several degrees of tilt would damage costly valanced or chrome trim as would loading the vehicle in tow without the ability to lower the underreach extension arm flat on the ground.

Zacklift's compact upright storage position brings the frame lift to within 8 inches of the tallboard when recessed and does not interfere with winching, boom operation or driver maneuverability around tallboard.

This expertly designed frame lift provides unsurpassed weight distribution because of **Zacklift's** tilt cylinder positioned directly over the rear axle. This location is the point at which the weight of the vehicle in tow is carried. The combination of mounting directly over the rear axle, recessed installation and light weight of the unit combine to provide thousands of extra pounds of payload.

Zacklift's medium duty wheel/frame lifts mount on any wrecker, mechanical or hydraulic. Because **Zacklift** does not require cables, chains or tow truck boom to function, the units can even turn a bare cab and chassis into a money making frame lift.

Zacklift customers report the mounting to be clean and easy; mounting securely to chassis frame rails not tallboard, without removing wrecker body. All units are engineered for recessed or outer tallboard mounting. The Z6500 and Z7000 are engineered for customers to install themselves by following step by step instructions provided with the **Zacklift**. Factory or dealer installation is also readily available.

Step out in front of the competition with damage free towing of everything from motorhomes to hard to tow cars. The industry's leader in retrofit technology will turn a truck you already own into a money making underlift at a fraction of the cost of a complete unit. And now the company that designed America's first retrofit wheel and frame lift brings you the easiest way to buy it. Simply call us today to find out about our over the phone single source leasing with 12 to 60 month terms to meet your needs. **Zacklift's** financing does not even require your truck be paid for nor does it limit financing because of year model. End of term full ownership, \$1.00 or 10% buyout. Even 90 day deferred payment available.

Don't risk damaging customer vehicles. Don't turn down business or lose it to the competition. There is a way to get top quality equipment: call us today.

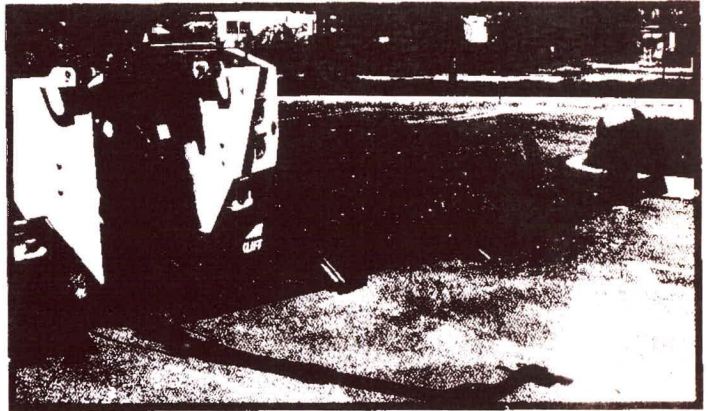

ZACKLIFT

